

RDC300 12.5A Low Voltage Dimmer Module – Installation and Operating Instructions.

General

The Rako RDC300 dimmer module is a low voltage dimmer designed to work from 24V and 12V dc power supplies. The output is pulse width modulated and is suitable for low voltage loads. The dimmer module is designed to be installed in a lighting circuit and is controlled from the range of Rako transmitting devices including the wall control panels and hand held units using Rakom encoded radio signals. Modules are supplied as standard with an external aerial. Units are available with internally mounted aerials by special order. Modules with internal aerials are designed for in-line mounting, particularly useful with free-standing and table lamps. External aerials offer a better reception range.

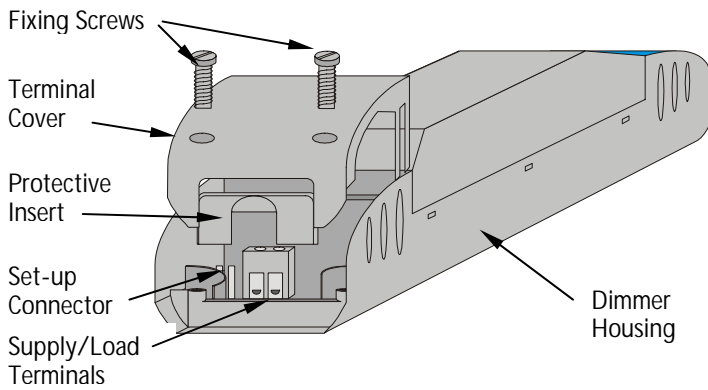

Fig 1.
Front View of Components

Installation

Before commencing installation of a Rako dimmer module first read this instruction manual carefully. Rako Controls Ltd accepts no responsibility for any damage or injury caused by incorrect installation of a Rako product.

Installation should only be carried out by a competent electrician.

Never attempt to connect a Rako dimmer or remove the terminal covers without first isolating the circuit at the fuse/MCB board.

The circuit supplying a Rako dimmer should always be protected by a suitably rated fuse.

Rako RDC300 dimmer module should be mounted in areas that are adequately ventilated, dry and outside of any enclosed metal casings. Wherever possible the modules should be securely fixed using the mounting holes provided. The mounting holes are blanked off when supplied but are designed so that a woodscrew will easily cut through without the need for drilling.

Whilst the Rako dimmer modules are designed to be completely maintenance free the units should be mounted in a position where access can be gained should there be a fault or re-addressing of the unit be necessary (see 'Set-up and Addressing').

Maximum loadings

300W at 24V DC
150W at 12V DC

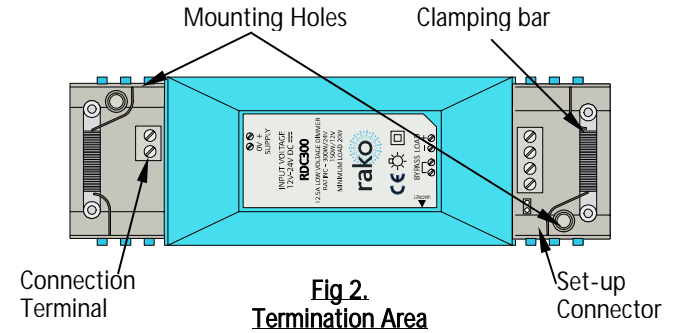

Fig 2.
Termination Area

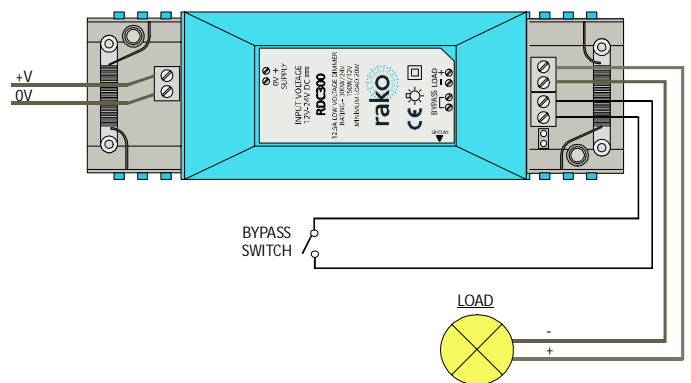

Fig 3.
Connection Detail

Note:

To ensure that the cable clamping operates satisfactorily the cabling both supplying the dimmer and to the load should be a minimum of 0.5mm² with double safety insulation and the wires should be stripped to ensure that the cable bar within the terminal cover clamps firmly on both sets of insulation.

To install a Rako dimmer module isolate the supply then remove the Terminal Covers (see Fig.1) giving access to the supply/load terminals. The necessary connections are indicated on the label on the dimmer housing. The notation is as follows:

Supply + +ve DC input
Supply 0V 0v DC input

Important : The polarity of the supply must not be reversed.

Load + +ve dimmed output
Load - -ve dimmed output

Bypass Connects the supply directly to the output via the 20Amp internal fuse.

Installation (continued)

Once the supply and load cables are connected ensure that the terminal covers are replaced and securely fastened, clamping the cable correctly as detailed above, before powering the unit.

Rako dimmer modules are not designed for loop in/loop out connections. Should it be necessary to loop the supply on to further fittings then a junction box should be connected in circuit to facilitate this.

With the supply and load connected and prior to switching on the supply ensure that the terminal covers are fitted and that they are securely clamping the cables. It is important to ensure that the protective inserts (see Fig.1) are fitted and located securely, both in the terminal cover and over the supply and load cables. The protective inserts provide important protection against the risk of electric shock from conductive objects forced down the side of the cables.

When power is connected the Rako unit will fade to a full-on setting. In this way it is possible to leave a conventional lighting switch in circuit to simply fade between full-on and off settings without the use of a Rako control panel. Such a lighting switch can also be used as an override in the event that the batteries in a Rako control panel are not replaced when the low-battery warning signals indicate that this should be done.

Set-up and Addressing

Before a Rako dimmer module will work with a Rako scene-sender control panel it must first receive an address identity from the control panel. To do this follow the set-up and addressing procedure as detailed below.

Setting an address is the way in which interference between other Rako systems, either with other rooms within your house or neighbouring houses is avoided. It should be remembered that with a booster unit a Rako transmitter may have a range of over 100m.

Your Rako control panel comes set with a default address of House 1, Room 4, Channel 1 and whilst the unit will function with this address it is strongly advised to select your own house address and logical room addresses. Fig. 4 illustrates how the house and room addressing avoids interference.

It should be noted that certain room addresses can have special functions. A panel set as Room 0 acts as an overall master control for all the rooms within a house. This may be useful if it is desirable to have a master control panel which controls all the rooms together, say for master On/Off panels at main entrances but should be avoided if master control is not intended. It is only possible to give panels the address of Room 0 and not receivers as a panel set to Room 0 will control all receivers in a house anyway.

It is also possible to have room grouping, see Fig.5 (only accessible using Rasoft software), whereby rooms are clustered into groups of 4 with the first address in each group acting as a master, therefore room 5 is a master for rooms 6,7, & 8, room 9 is a master for rooms 10, 11 & 12 and so on. This may be a useful feature if, for example, bedside lighting needs individual control but still needs to be turned off at the main bedroom panel at the door. Room 0 still acts as an overall house master as well as for its own group of rooms 1,2 & 3. As room grouping may become desirable at a later stage it is recommended to avoid setting room addresses to those which would become slave rooms within a group. This is done by leaving room address switches 1 & 2 in the off position, see Fig. 6.

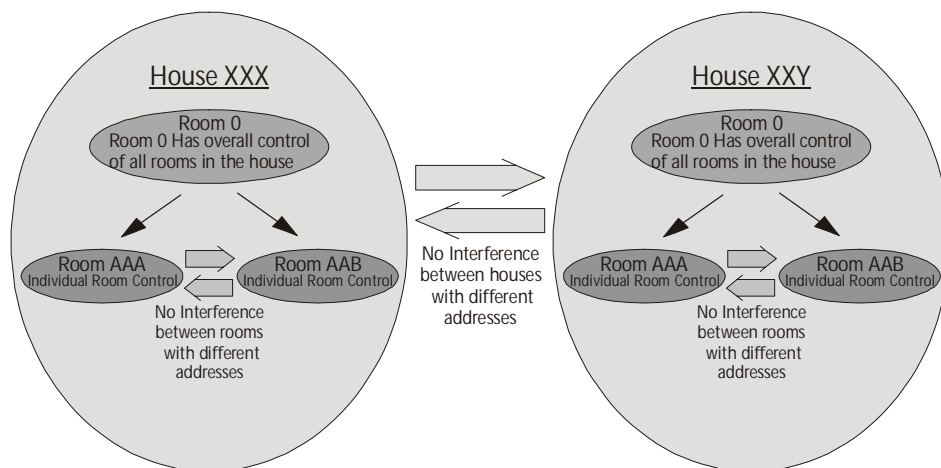

Fig 4.
Rako house and room addressing

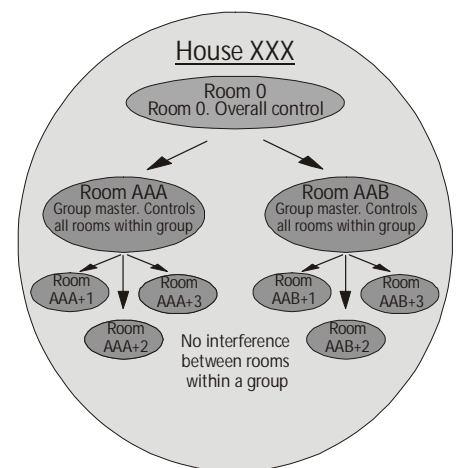
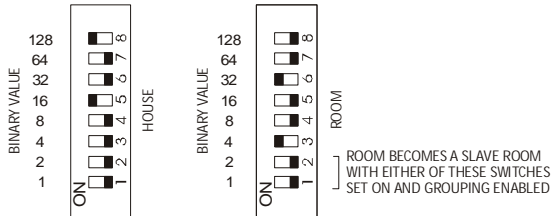

Fig 5.
Rako addressing with grouping enabled.

Setting an Address

Each Rako transmitter has two, 8 way banks of switches for setting its address. The two sets of switches allow the user to choose from 256 house addresses and 256 room addresses (64 groups of 4 with grouping enabled). To set the address, unclip the rear cover whereupon the banks of switches will be now become visible. To set an address, use a small terminal screwdriver or similar device and carefully move some of the switches into the 'ON' position. Addressing uses binary encoding and the value of the switches is shown below.



House address
= 128+16=144

Room address
= 32+4=36.

Fig 6.
Addressing Switches

Once the addresses have been set it is strongly recommended to keep a note of the settings and to keep these in safe place. Whilst it is easy to set the addresses, those of the receiver units are normally only set once. To do so requires access to the units and once set these may be installed in inaccessible positions. If, therefore the wall-plate address get changed for any reason and the original settings cannot be remembered then access to the receiver units will be needed for reconfiguration.

Note:

Once the address for a control panel has been set the transmitter, or at least one transmitter within a room, needs to send its address to all the receiver modules that it needs to control. This can either be done before or once the control panel has been installed.

Setting receiver addresses.

Receiver modules not only have house and room addresses but also a channel address, which can be set from 1-15 for each room. This channel address is what allows different circuits to be set at different levels for each scene. Setting all of these addresses is achieved by a single command from a wall-plate in programming mode. The procedure for setting the receiver address is as follows. See the relevant section for details on each step.

- Put wall-plate into programming mode.
- Find an available channel.
- Put receiver into set-up mode.
- Press the ident button.
- Exit programming mode on wall-plate.
- Exit set-up mode on receiver (done automatically when using the magnet method).

Putting Wall-plate into programming mode.

Press and hold a scene button (one of the four numbered buttons on the left hand side of the plate) and at the same time press and hold both the raise and lower buttons (the right hand buttons). After 3 seconds the LED will start to flash, the plate is now in programming mode. To exit programming mode press the Exit button (see Fig. 8).

Note:

If the Exit button is not pressed or any other buttons pressed the panel will exit from programming mode automatically after 3 minutes.

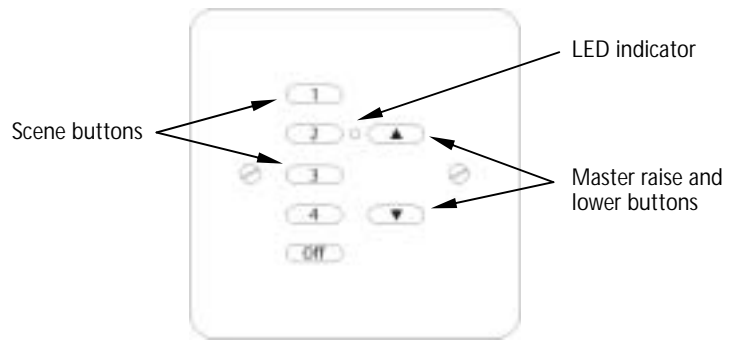

Fig 7.
Wall-plate buttons in normal mode

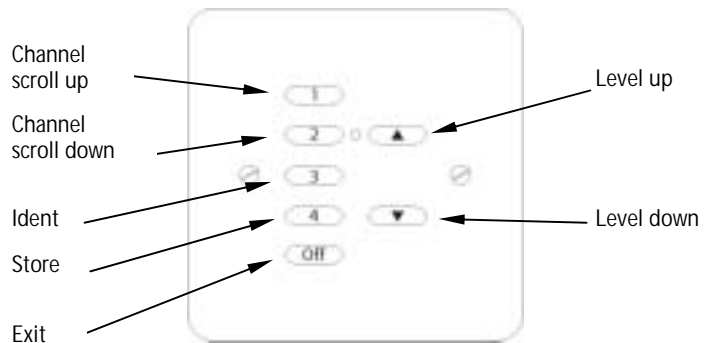

Fig 8.
Wall-plate buttons in programming mode

Setting a receiver's address.

The first step is to find an available channel address for the receiver. For convenience, this is usually the next available channel after all the already allocated addresses. To identify which channels already have allocated addresses first put the wall-plate into programming mode. Then, using the Channel scroll up and Channel scroll down keys scroll through the 15 available channel addresses. When a channel address is reached which already has a receiver allocated, that receiver will flash its load in a slow double pulse to identify itself. Channel 0 will flash all the channels in a fast quadruple flash indicating the start point (note: it is not possible to program a receiver to channel 0. Scroll through until you find an available channel i.e. a channel where no load flashes, or to another specific channel that you wish to set the receiver to and then stop. This is the channel identity that will be sent to the receiver when the Ident key is pressed. Next put the receiver into set-up mode (see putting receiver into set-up mode) and then press the Ident button. The receiver will flash its load to acknowledge receipt of the command and then automatically drop out of set-up mode (unless using the header connector method, see notes). The receiver has now registered the house, room and the specific channel address that it should respond to. If no more set-up commands are to be sent by the wall-plate then press the Exit key to return the panel to normal operating mode.

Note:

For ease of use it is generally advisable to set the channel addresses in a sequence from channel 1 onwards. It is possible to set two receivers to the same channel address. This has been deliberately made possible, as it may be desirable to have two receivers that always respond together fading to exactly the same lighting levels. For example there may be two identical up-lighters, both fed from independent receivers, which need to always respond as one.

Putting the Receiver into set –up mode.

Firstly ensure that the receiver has been connected correctly, that the unit is powered up and that a suitable lighting load is connected. Using the small magnet provided with each receiver, press the magnet against the receiver casing just over halfway down (see Fig.9). The approximate position for this is indicated by the 'magnet point' legend on the top label. When the magnet is in the correct position an internal LED will illuminate. The LED will stay on with a steady illumination all the time that the magnet is in the correct position. Hold the magnet in this position for 3 seconds until the LED starts to flash. The receiver is now in set up mode.

Approximate position for Rako programming magnet.

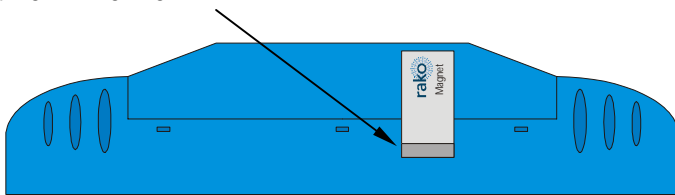

Fig 9.
Set-up Magnet Positioning

Note:

If no commands are received from the wall-plate within 3 minutes the receiver will automatically come out of set-up mode. The receiver will also come out of programming mode if the power to the unit is interrupted.

Programming a lighting scene.

To program a scene firstly choose which scene is to be programmed or re-programmed. Press and hold that scene button and at the same time press and hold both the master raise and lower buttons. After 3 seconds the panel will go into programming mode and the LED will start to flash. Next, using what are now the Channel scroll up and down buttons, scroll through to a channel whose level needs to be altered. As the channels are scrolled through they will each, in turn, flash their loads to indicate which is the current channel. At any time pressing the ident button will flash the currently selected channel without scrolling on. When the appropriate channel has been reached use the channel raise lower buttons to alter the lighting level for that load. Scroll through the remaining channels changing the lighting levels until the desired scene has been set. Pressing the store button will save all current levels to that scene and all the receivers should now flash their load again to confirm that the levels have been stored. Press the Exit key to return the Wall-plate to normal mode.

Note: When re-programming a lighting scene it is quite possible to enter programming mode, select and alter only one or two channels and re-set their levels without adjusting any of the remaining channels. Thus fine tuning a scene becomes a simple and easy task.

Care and maintenance

General

Rako thanks you for having purchased a Rako product and hopes that you are pleased with your system. Should for any reason you need to contact us please contact us via our website www.rakocontrols.com or by phoning our customer help line on 0870-043-3905.