

# RCP02/5 2 and 5 Push button wall plates – Installation and Operating Instructions.

## General

**Note:** The RCP02 and RCP05 scene sender panels are for scene recall only. The scene programming function is not accessible from these panels. Programming must be done either from an RCP07 set to the same address or by using the RASOFT software.

The Rako RCP series of wall-plates are designed to cope with a number of different installation situations.

These are predominantly:

Flush fixing into a UK back-box.

Surface mounting with a UK back-box

Surface mounting with no back-box or onto a European DIN standard or French box.

In order to fit successfully into all the above situations the wall-plate is made from an assembly of parts, all of which are supplied as standard and are listed below. The parts can also be identified from the drawing Fig1. The front plates for the 2 and 5 push button plates are ordered separately and are only available in metal finishes.

(Note: Depending on the application not all of the parts may be used)

- |  |   |
|--|---|
| 1 x Front plate. (Ordered separately                 | 2 x 6mm M3.5 fixing screws.                         |
| 1 x PCB retainer (complete with PCB and button pad). | 2 x 25mm M3.5 fixing screws.                        |
| 1 x Rear cover.                                      | 2 x 12mm M3.5 fixing screws.                        |
| 1 x Patress.   | 2 x self-tapping screws.                            |
| 1 x Universal backing plate.                         | 1 x Terminal block (permanent supply versions only) |

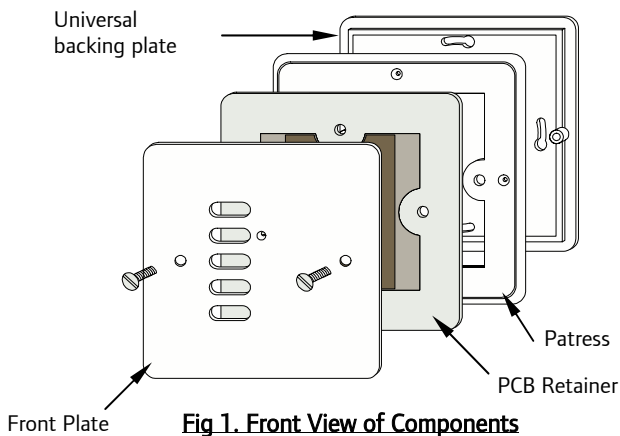

**Fig 1. Front View of Components**

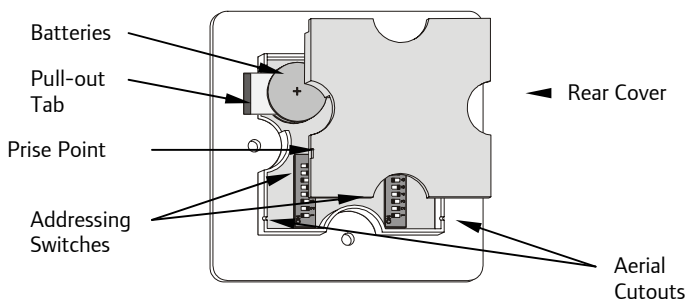

**Fig 2. Rear View of PCB Retainer and Rear Cover**

## Setting Up and Addressing the Units

### Important

**This section must be read and followed before installation of the Rako control panel.**

Your Rako control panel is supplied with a pullout tab to prevent inadvertent operation and battery deterioration during transit. To remove this and to access the address switches remove the rear cover.

### Rear cover removal.

Insert the tip of a small screwdriver or similar into the prise point (Fig. 2) and gently lift off the rear cover. This should expose the battery compartment and addressing switches. Care should be taken not to touch or otherwise damage any of the exposed electronic components.

### Checking for correct operation

With the rear cover removed pull out the tab protecting the batteries (see Fig.2); your Rako control panel should now be operational. To check this press one of the buttons on the front of the PCB retainer and the indicating LED should illuminate briefly for a single flash. If the LED does not flash or it flashes repeatedly for a short burst (low battery warning) then you should contact Rako controls on the number given below.

### Addressing

Setting an address is the way in which interference between other Rako systems, either with other rooms within your house or neighbouring houses is avoided. It should be remembered that with a booster unit a Rako transmitter may have a range of over 100m.

Your Rako control panel comes set with a default address of House 1 Room 4 and whilst the unit will function with this address it is strongly advised to select your own house address and logical room addresses. Fig. 3 illustrates how the house and room addressing avoids interference.

### Special Addresses

It should be noted that certain room addresses can have special functions. Room 0 acts as an overall master control for all the rooms within a house. This may be useful if it is desirable to have a master control panel which controls all the rooms together, say for master On/Off panels at main entrances but should be avoided if master control is not intended.

It is also possible to have room grouping, see Fig.4 (only accessible using Rasoft software), whereby rooms are clustered into groups of 4 with the first address in each group acting as a master, therefore room 5 is a master for rooms 6,7, & 8, room 9 is a master for rooms 10, 11 & 12 and so on. This may be a useful feature if, for example, bedside lighting needs individual control but still needs to be turned off at the main bedroom panel at the door. Room 0 still acts as an overall house master as well as for its own group of rooms 1,2 & 3. As room grouping may become desirable at a later stage it is recommended to avoid setting room addresses to those which would become slave rooms within a group. This is done by leaving room address switches 1 & 2 in the off position, see Fig. 5.

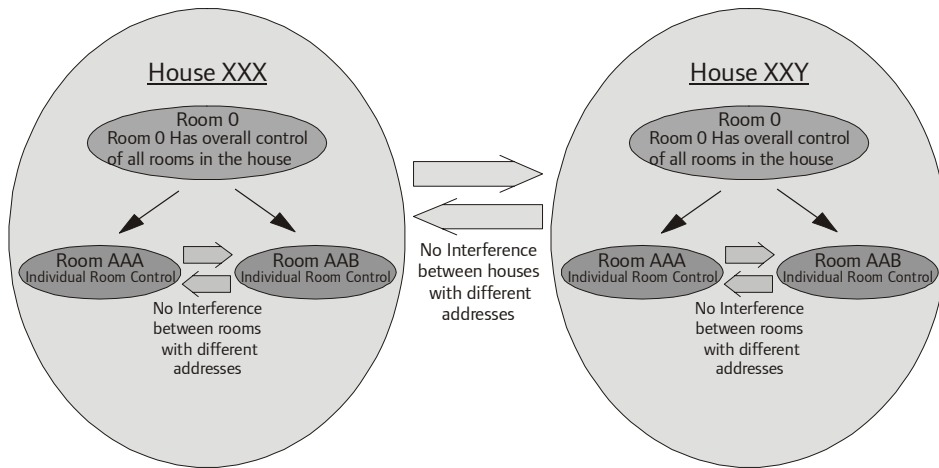

**Fig 3.**  
**Rako house and room addressing**

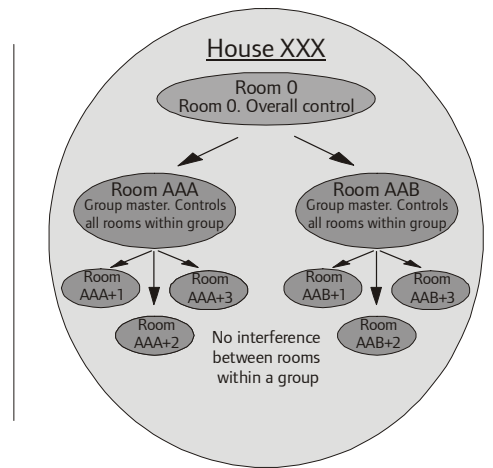

**Fig 4.**  
**Rako addressing with grouping enabled.**

**Setting an Address**

Each Rako transmitter has two, 8 way banks of switches for setting its address. The two sets of switches allow the user to choose from 256 house addresses and 256 room addresses (64 groups of 4 with grouping enabled). To set the address, unclip the rear cover whereupon the banks of switches will be now become visible. To set an address, use a small terminal screwdriver or similar device and carefully move some of the switches into the 'ON' position. Addressing uses binary encoding and the value of the switches is shown below.

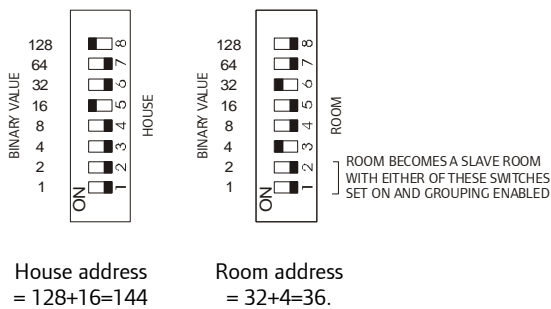
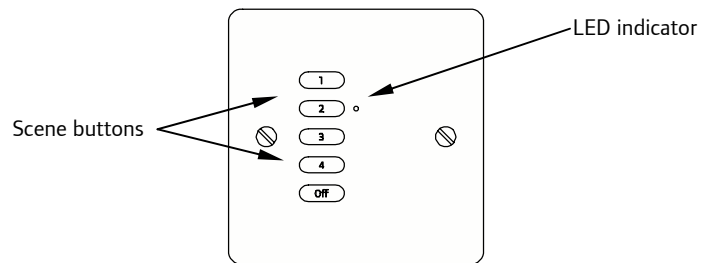

**Fig 5.**  
**Addressing Switches**

Once the addresses have been set it is strongly recommended to keep a note of the settings and to keep these in safe place. Whilst it is easy to set the addresses, those of the receiver units are normally only set once. To do so requires access to the units and once set these may be installed in inaccessible positions. If, therefore the wall-plate address get changed for any reason and the original settings cannot be remembered then access to the receiver units will be needed for reconfiguration.

**Note:**

Once the address for a control panel has been set the transmitter, or at least one transmitter within a room, needs to send its address to all the receiver modules that it needs to control. This can either be done before or once the control panel has been installed.



**Fig 6.**  
**RCPO5 Wall-plate buttons**

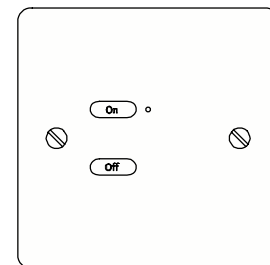

**Fig 7.**  
**RCPO2 Wall-plate variant**

**Installation**

Before assembly ensure that the rear cover is firmly fixed and that the aerial is positioned in a way as to not foul other components.

**Warning**

Rako wall-plates are designed to operate at safety extra low voltages (6V). When fixing the wall-plates to existing back-boxes there may be mains wiring present, if this is the case then the wiring should be made safe, properly insulated and any metal back-boxes earthed. Earthing of the back box is essential if a decorative metal front plate is being used. Should there be any doubt in how to do this contact a qualified electrician.

Rako Controls Ltd accepts no responsibility for any damage or injury caused by incorrect installation of a Rako product.

### **Surface fixing to UK back box.**

Orientate the patress so that the bossed inserts are aligned vertically and locate the PCB retainer in the patress. Then using the 25mm fixing screws fix the front plate to the retainer and patress and back-box.

### **Flush fixing to a UK back-box**

Fit the PCB retainer in the back-box so that the clear flange is flush to the wall. Then using the 12mm fixing screws (or 25mm if needed) secure the front plate to the PCB retainer and back-box.

Note. If a metal front plate is being used, as per the Rako RPP accessories, then the aerial must be positioned outside of the back-box. This is because the front plate and back-box will form a 'Faraday cage', which will give very poor radio transmitting conditions. To position the aerial correctly a hole must be cut in the back-box and a small diameter hole drilled into the wall. Straighten the aerial and push the aerial into the hole. The best radio transmission will be achieved when all of the aerial fully extended and outside of the back-box. If, because of physical constraints, it is not possible to drill the hole in a position close to where the aerial emerges from the PCB retainer, then the rear cover can be removed and the aerial re-positioned in a more convenient aerial cut-out (see fig 2).

### **Surface fixing with no back-box**

Take the universal backing plate and screw this to the wall (screws not included) using the fixing slots. Rotate the patress so that the bossed inserts are aligned horizontally and then, using the 2 x self-tapping screws, fix the patress to the universal backing plate taking sure not to over-tighten the screws. Insert the PCB retainer into the patress and then using the 2 x 6mm fixing screws, secure the front plate to the patress fixing the screws through the PCB retainer and into the bossed inserts.

### **Surface fixing to European back-boxes.**

For fixing to European DIN or French standard back-boxes the Rako universal backing plate has been designed so that two of the fixing slots match European DIN standard back-box fixings and two match standard French back-box fixings. To mount the assembly, orientate and mount the universal backing plate as applicable (screws not provided) and then follow the instructions for 'Surface fixing with no back-box'.

## **Care and maintenance**

### **Battery replacement**

The Rako RCP series of wall-plates are designed to be powered by batteries. The designed battery life is better than 3 years (based on 30 button presses daily) but the batteries will eventually need replacing. In normal use the Led on the front panel illuminates momentarily when a button is pressed to indicate that a (radio) transmission has been made. When the batteries are approaching the end of their useful life the Led will continue to blink after a button has been pressed. When this starts to happen the batteries should be replaced as soon as possible.

### **Always use two CR2016 type batteries.**

To replace the batteries unscrew the front plate and remove the PCB retainer, taking care not to damage the aerial (note that when flush mounted the aerial may be located in a hole outside the back-box). Remove the rear cover and carefully slide out the batteries. Replace with new batteries ensuring that the positive (+) terminal makes contact with the battery clip and the negative (-) terminal with the pad on the circuit board.

To ensure reliable operation always ensure that battery contacts and battery surfaces are kept clean of any grease, moisture or other contamination.

### **Warning**

**Lithium batteries may explode if handled incorrectly. Always dispose of used batteries in accordance with manufacturer's recommendations.**

### **General**

Rako thanks you for having purchased a Rako product and hopes that you are pleased with your system. Should for any reason you need to contact us please contact us via our website [www.rakocontrols.com](http://www.rakocontrols.com) or by phoning our customer help line on 0870-043-3905.