

OMX-CI-RS232 Control Interface



Description

- Integrates GRAFIK 5000/6000/7000, *Softswitch128*, and *LCP128* systems with a touchscreen or other digital equipment that supports RS232 communication.
- Provides monitoring commands that allow a touchscreen to query lighting systems to:
 - Determine which scene is selected.
 - Keep track of buttons pressed.
- Provides control commands that allow a touchscreen to operate lighting systems to:
 - Select or sequence lighting scenes.
 - Raise or Lower one or more zones.
 - Lock lighting controls.
 - Activate panic mode (lights go to full on).
 - Simulate button actions
 - Disable or Enable timeclock(s)

Job Name:	Model Numbers:
Job Number:	

Specifications

Power

- Low-voltage PELV (Class 2: USA).
- Operating voltage: 24 V_{DC}.

Uses OMX RS232 Command Set

- Monitoring: Scene selection and scene status updates.
- Control: Scene selection, scene lockout, sequencing, zone lockout, zone raise/lower.

System Communications and Capacity

- Low-voltage PELV (Class 2: USA) wiring connects OMX-RS232 Interface to Processor Panel.
- Multiple OMX-RS232 Control Interfaces may be used.
- 50 ft. (15 m) maximum from OMX-RS232 Interface to PC or other RS232 source.

Environment

32-122°F (0-50°C). Relative humidity less than 90% non-condensing.

Dip Switch Settings

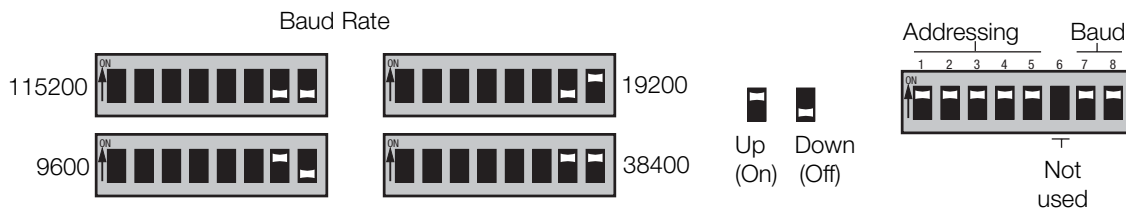
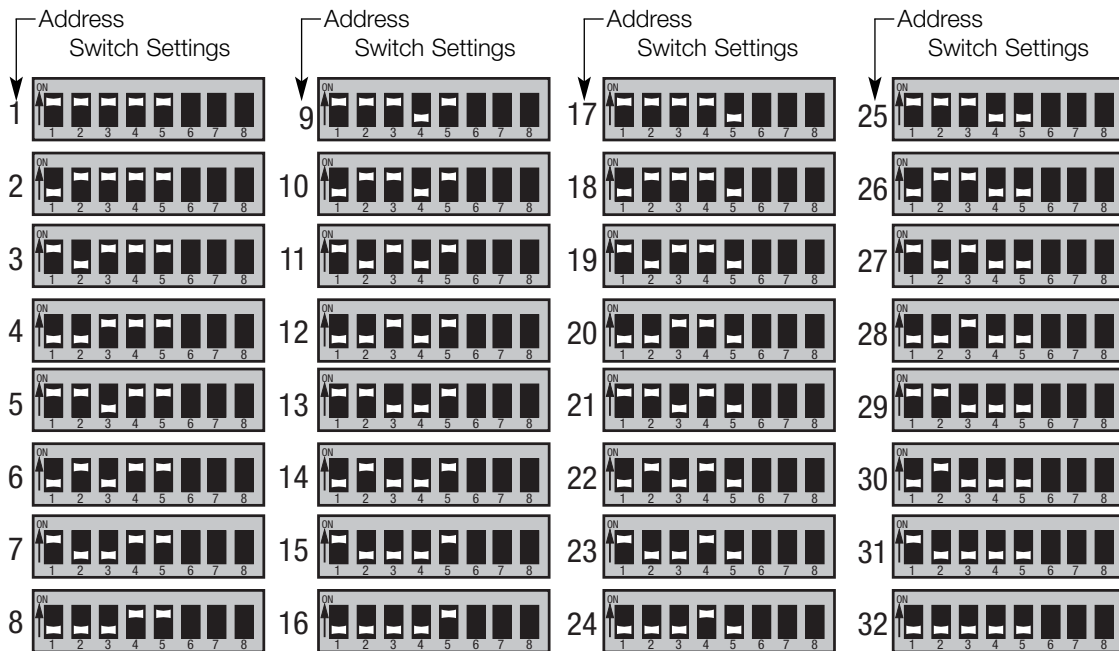

Job Name:	Model Numbers:
Job Number:	

Dimensions

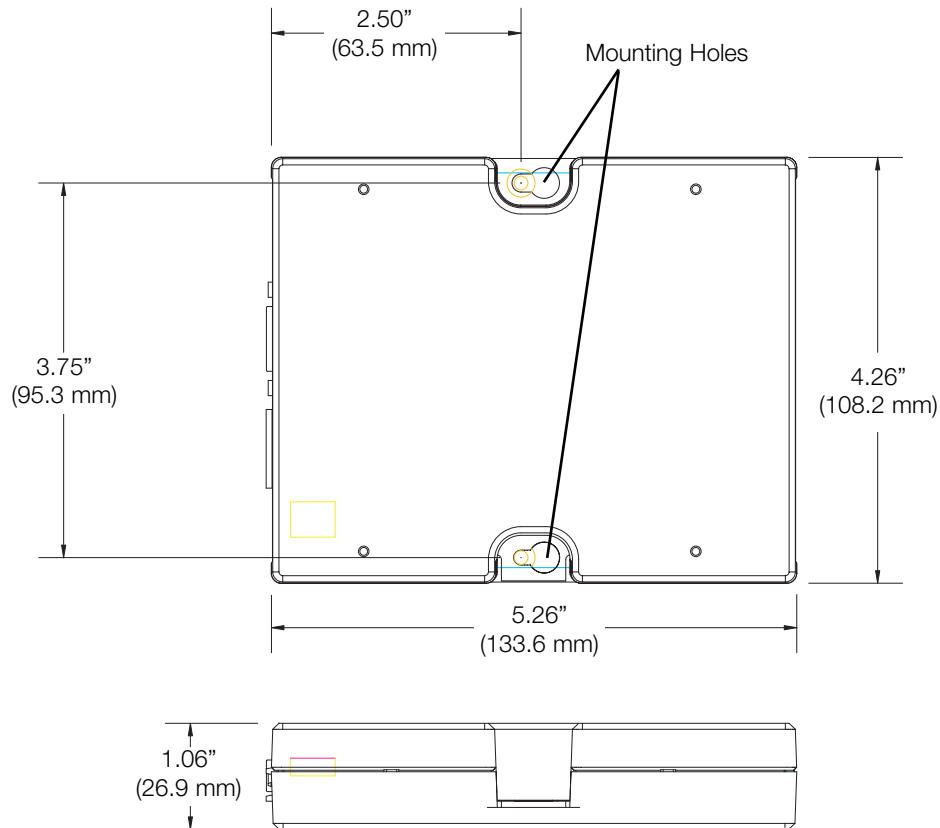

Mounting

1. Mount the Control Interface directly on a wall, as shown in the Mounting Diagram, using screws (not included). When mounting, provide sufficient space for connecting cables.

The unit can also be placed in the LUT-19AV-1U AV rack using the screws provided with the unit. The LUT-19AV-1U will hold up to four units.

2. Strip 3/8 in. (10 mm) of insulation from wires. Each Data Link terminal will accept up to two #18 AWG (1.0 mm²) wires.
3. Connect wiring as shown in the Wiring Diagram (next page). LED 1 lights continuously (Power) and LED 7 blinks rapidly (Data Link RX) when the PELV (Class 2: USA) Data Link is installed correctly.

Mounting Diagram

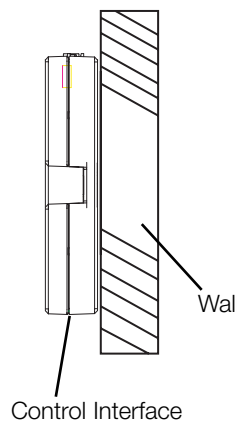

LUT-19AV-1U

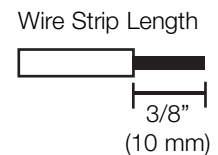

<p>Job Name:</p>	<p>Model Numbers:</p>
<p>Job Number:</p>	

RS232 Link Wiring

- Use cable provided.
- Standard 9-pin serial connector plugs into RS232 equipment, other end connects to RS232 Link terminals.
- Must be 50 ft. (15 m) or less.

RS232 Signals

OMX-RS232 Link Terminal	Signal	Typical PC or A/V Equipment	Pin on 9-pin Cable
1	Common	Com	5
2	Data In	TxD	3
3	Data Out	RxD	2
4	No Connect		
5	No Connect		

Low-Voltage PELV (Class 2: USA) Wiring

- Daisy-chain the OMX-CI-RS232 Interface to the PELV (Class 2: USA) Wallstation Link that connects to the Processor Panel.
- Make daisy-chain connections to the low-voltage PELV (Class 2: USA) Data Link terminals on the front of OMX-CI-RS232 Interface.
- Do not use T-taps. Run all wires in and out of terminal block.
- Each terminal accepts up to two #18 AWG (1.0 mm²) wires.
- LED 1 lights when the PELV (Class 2: USA) Data link is installed correctly.
- Consult Processor Panel Specification Submittal for more details.

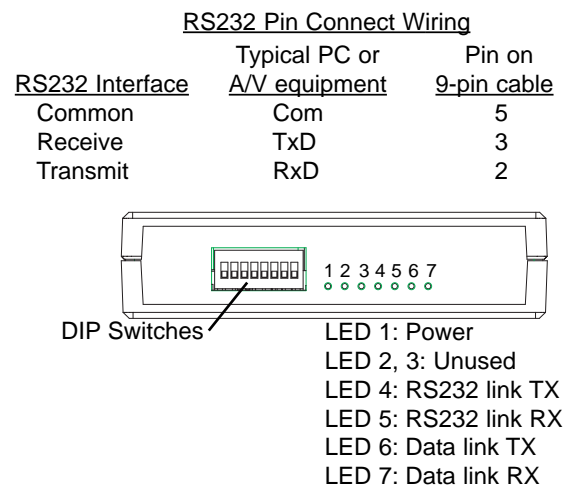
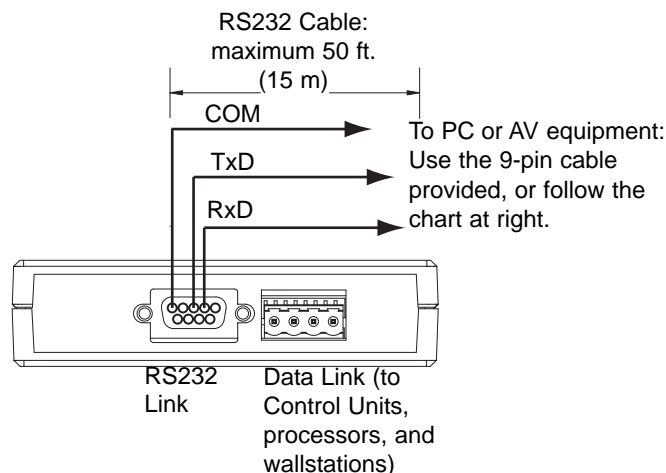

Job Name:	Model Numbers:
Job Number:	

PELV (Class 2: USA) Terminal Connections

- Two #12 AWG (2.5 mm²) conductors for common (terminal 1) and 24 V_{DC} (terminal 2). These will not fit in terminals. Connect as shown.
- One shielded, twisted pair #18 AWG (1.0 mm²) for data link (terminals 3 and 4).
- Connect Drain/Shield as shown. Do not connect to Ground (Earth) or Wallstation/Control Interfaces. Connect the bare drain wires and cut off the outside shield.

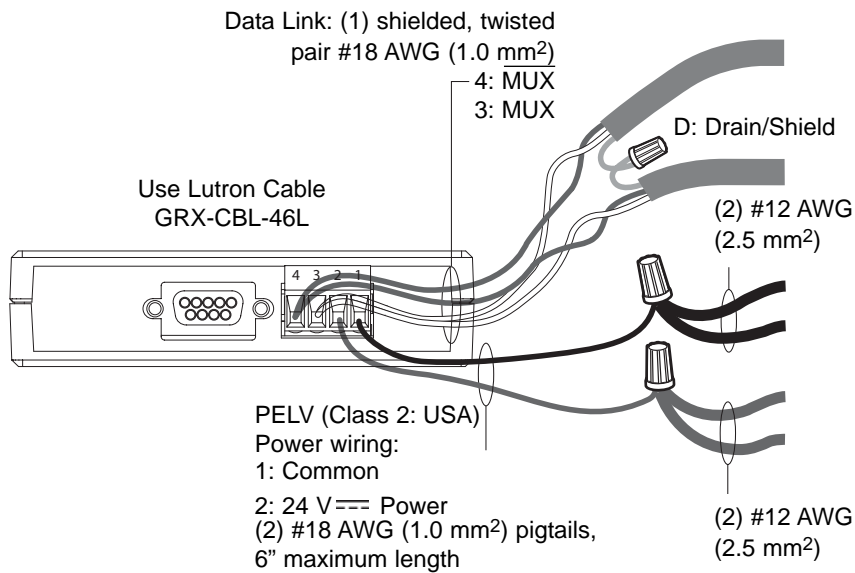

Note: Do not connect Drain/Shield to Ground (Earth) or Wallstation/Control Interfaces. Connect the bare drain wires and cut off the outside shield.

Note: #12 AWG (2.5 mm²) conductors for Common (terminal 1) and 24 V_{DC} Power (terminal 2) will not fit in terminals; use #18 AWG pigtails (< 6").

Job Name:	Model Numbers:
Job Number:	