

Slim and Large Button Keypads – Wiring and Mounting

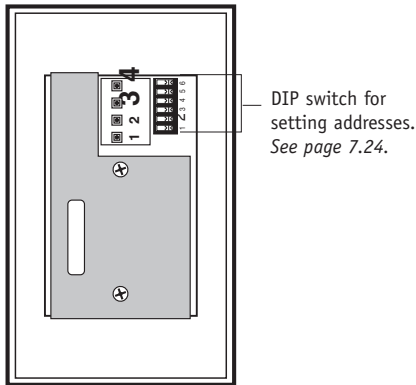

Figure 1 – keypad rear view

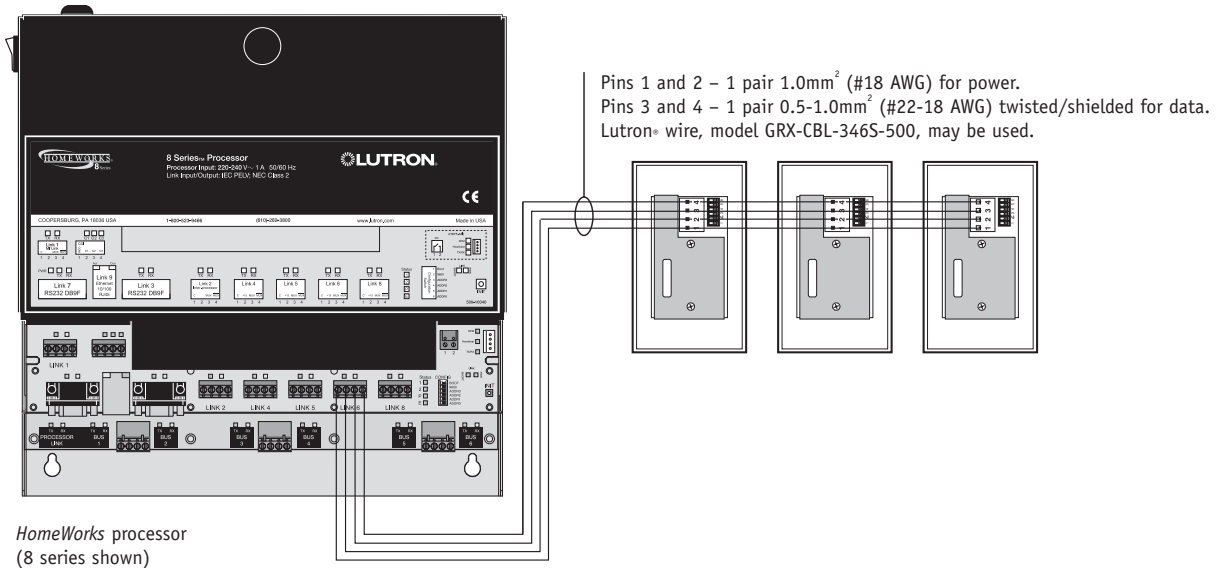

Figure 2 – wiring diagram

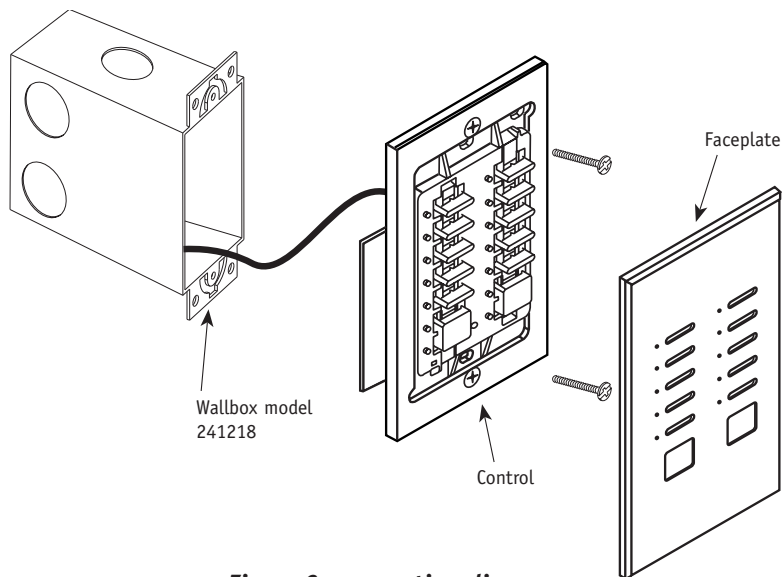

Figure 3 – mounting diagram