



MASTERLine ES 30W GU5.3 12V 36D 1CT

Product family description
MASTER dichroic coated low-voltage halogen reflector lamp with EcoBoost technology: the most energy-efficient dichroic lamp on the market

Product Features

- Unique Philips patented infrared-coated single-ended burner by using EcoBoost technology with 40% higher efficiency than standard products
- Heat-reflecting coating on the inner lamp burner reflects heat back to the filament so less energy is needed to operate the lamp
- Revolutionary compact and precision-shaped single-ended burner and high-performance coating for maximum lamp performance
- Extreme long average rated life
- GU5.3 base for extra retention in luminaire
- Complex reflector design for excellent beam performance
- Range of energy saving wattages to replace the higher standard wattages

Product Benefits

- Lowest possible energy and maintenance costs while maintaining light levels
- Lowest possible heat production
- Bright, sparkling white halogen light with excellent colour rendering

- Replaces standard and high-end dichroic reflector lamps
- Energy savings of up to 40% compared with standard dichroics
- Increased comfort and (where applicable) lower cooling costs through up to 40% lower heat transmission
- Up to 66% more lifetime (5000 hours) compared with standard conventional halogen dichroics
- Lowest dichroic UV output reduces fading risks to an absolute minimum

Application

- Accent and general lighting applications in homes, shops, hotels and restaurants, where energy efficiency and low maintenance are important
- Art galleries, museums and exhibitions

Luminaires

- Can be used in luminaires without front glass in accordance with IEC 598

Product data

Order code	413789 71
Full product code	871150041378971
Full product name	MASTERLine ES 30W GU5.3 12V 36D 1CT
Order product name	MASTERL ES 30W GU5.3 12V 36D 1CT/4X5F
Packing type	1 Lamp in a Folding Carton
Pieces per pack	1
Packing configuration	4X5F
Packs per outerbox	20
Bar code on pack - EAN1	8711500413789
Bar code on intermediate packing - EAN2	8711500413796

Product data	
Bar code on outerbox - EAN3	8711500410047
Logistic code(s) - 12NC	9240 462 17106 9248 953 17101
ILCOS code	HRGS- 30- 12- GU5.3- 50/36
Net weight per piece	30.000 (GR)
Successor order code	
Rated Lamp Wattage[W]	30W
Cap- Base	GU5.3
Voltage[V]	12V
Beam Angle[D]	36D
Philips Code	18136
ANSI Code Halogen	na[-]
Bulb	MR16[MR 16inch/50mm]
Burning Position	any[Any/Universal]
Luminous Intensity[cd]	1600
Colour Rendering Index[Ra8]	100
Colour Temperature[K]	3000

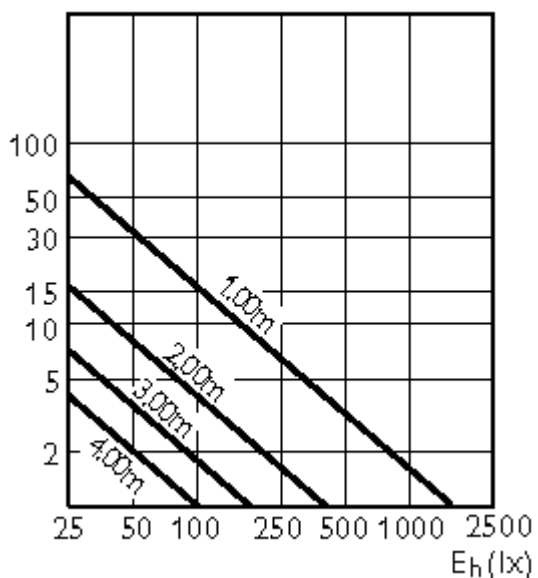

MASTERL ES 30W 36D

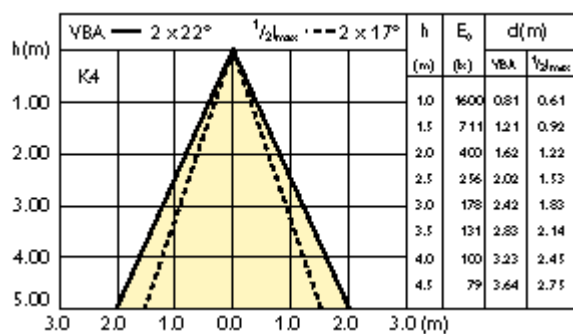

MASTERL ES 30W 36D

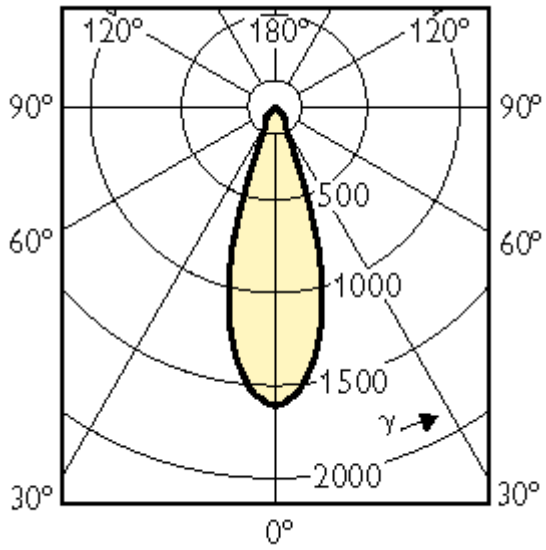

MASTERL ES 30W 36D

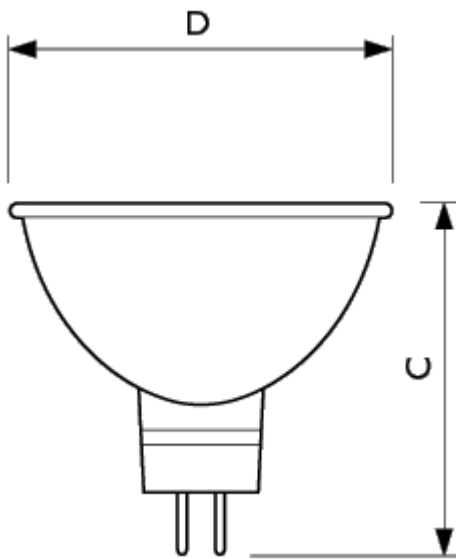

MASTERL ES
18132/18133/18134/18135/18136/18137/18138/18139/
18140/18141/18142/18143/18144/18145/18146

	C1	D
Full product name	Max	Max
MASTERLine ES 30W GU5.3 12V 36D 1CT	50.5	51

